

ASR

WORMWHEEL
UNLOCK
DEVICE

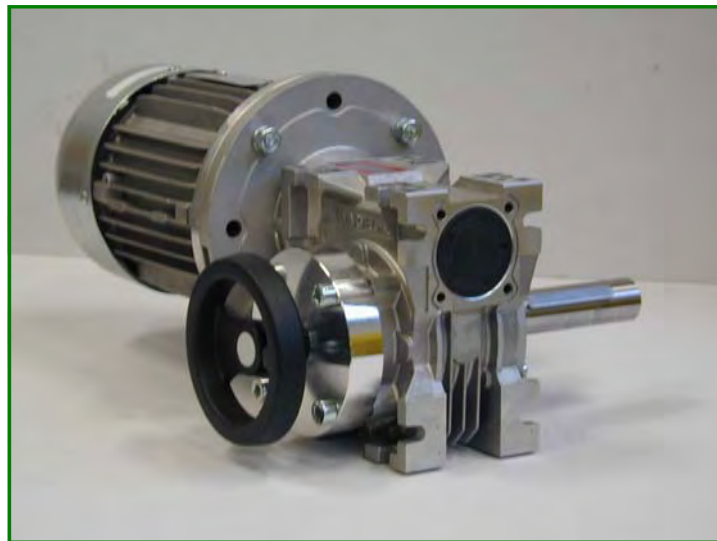

ASR - Worm Speed Reducers
types RS and RT

VARVEL - ASR

WORM WHEEL UNLOCK DEVICE - SERIE ASR

The unlock device is incorporated inside a standard wormwheel speed reducer of the series RT or RS, sizes 28 to 85 and all the reduction ratios, IEC motor mountings, output shafts, etc. according to their specific catalogues.

The clutch is manufactured to be driven

- manually by hand wheel;
- manually by lever;
- electrically by electromagnet for remote control.

The output shaft is made only as single sided spindle and is supplied as standard with the same dimensions of the output shaft AS.

The control can be activated when stand-still, on operation and also on load conditions with an adequately sizing of unlocking force.

The electromagnet remote control can be connected to the gearbox motor for an automatic unlocking at power failure or separately to a separate auxiliary battery for an independent unlock.

DRIVES

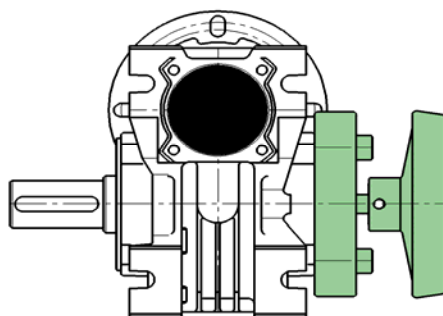

Hand wheel

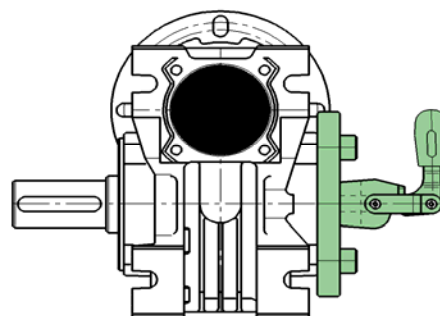

Lever

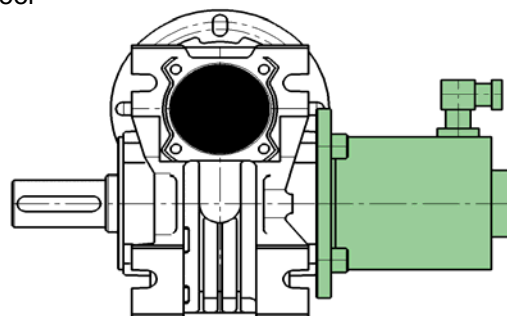

Electromagnet

VARVEL - ASR

MANUFACTURING VERSIONS AND POSITIONS

Manufacturing versions

The gear boxes with ASR unlock device are supplied with the wormwheel of spheroidal-graphite cast iron GS500 - fully dimensioned in the majority of intermittent applications for sliding door and gate driving, but with different torque values from those shown in the relevant catalogues RS and RT.

A bronze wormwheel is supplied on demand for those cases where the requested torque or duty cycle are particularly severe. .

Manufacturing positions

The following mounting positions are available:

SX - standard position

left side when looking from electric motor.

DX - on demand position

right side when looking from electric motor.

The above mounting positions are valid for any of the three driving types.

The gearboxes with unlock device can work according to all the installation positions provided for by the relevant catalogues.

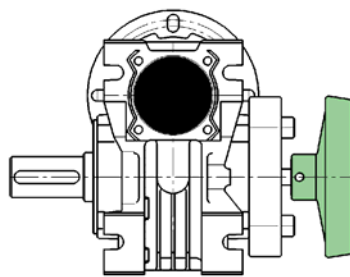

SX
Standard

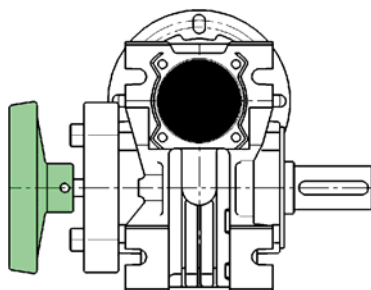

DX
On demand

VARVEL - ASR

WORKING PRINCIPLE

The torque transmission between worm wheel and output shaft is guaranteed by a key/keyway locking that can axially shift to allow the consequent application lock/ unlock .

Unlocking

In the blocked transmission situation, the wheel (02) is integral with the output shaft (01) by the means of the key (06).

The handwheel (07) rotation (lever or solenoid de-energizing) causes the shaft (03/04) shifting towards the gearbox inside, pushes the key out from its keyway in the gear and makes the output shaft

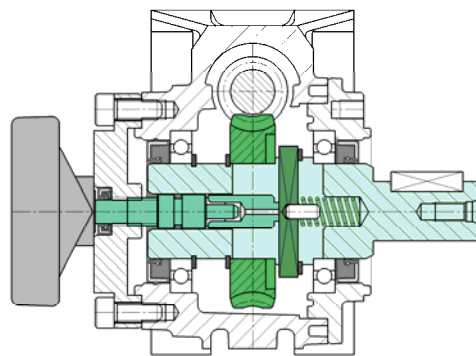

Unlocking

Locking

In the previously unlocked transmission situation, the wheel (02) and the shaft (01) are not connected by the key (06) and the output shaft is idle.

The counter-rotation of the handwheel (lever or solenoid energizing) origins the shaft (03/04) shifting towards the gearbox outside and the spring (11) forces the key to automatically re-enter into its keyway of the wormwheel.

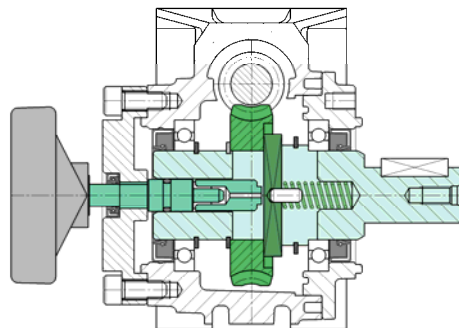

Locking

NB - The above reference numbers are traceable in the table of Part List at page 7.

VARVEL - ASR

CLUTCH TYPES

Key clutch frontal fit

Standard execution.

The motion transmission between the wormwheel and output shaft takes place by a frontal key clutch. This operation meets the majority of applications with locking/unlocking steps every 180° .

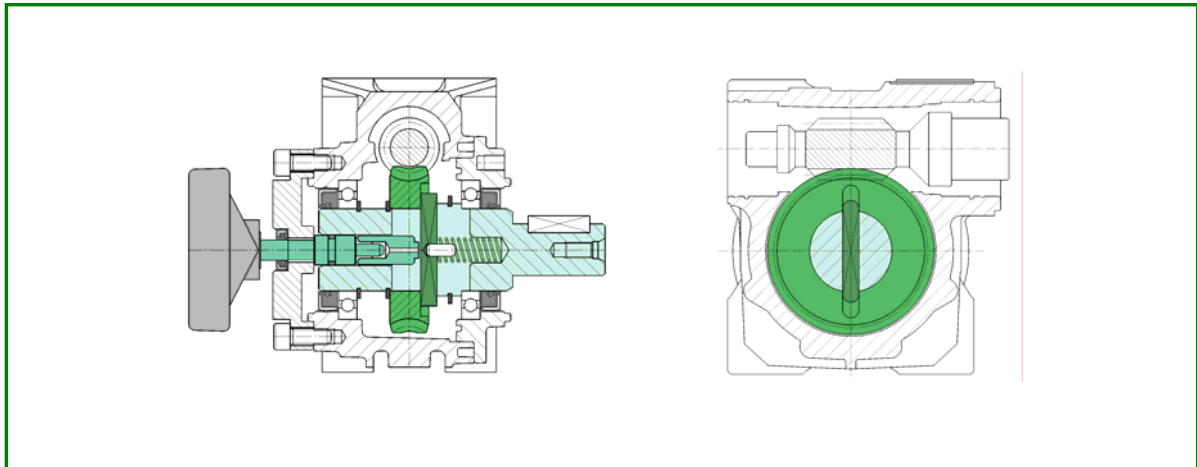

Claw clutch frontal fit

Execution on demand.

The motion transmission between the wormwheel and output shaft takes place by a claw clutch. Locking/unlocking intervention time is reduced in comparison with one key clutch and the tooth number fixes it accordingly. Usually, 40 teeth are used to get locking/unlocking every 8° .

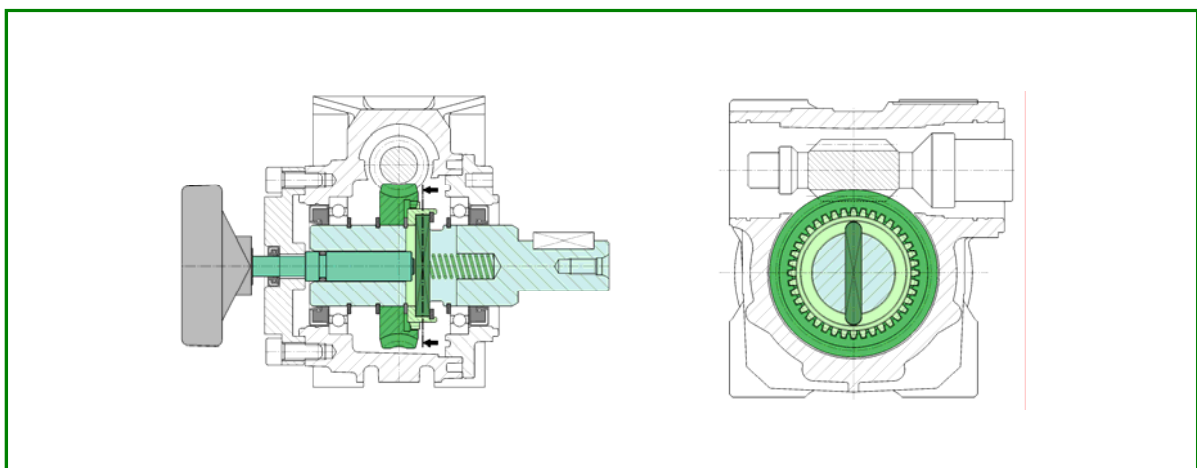

VARVEL - ASR

DIMENSIONS

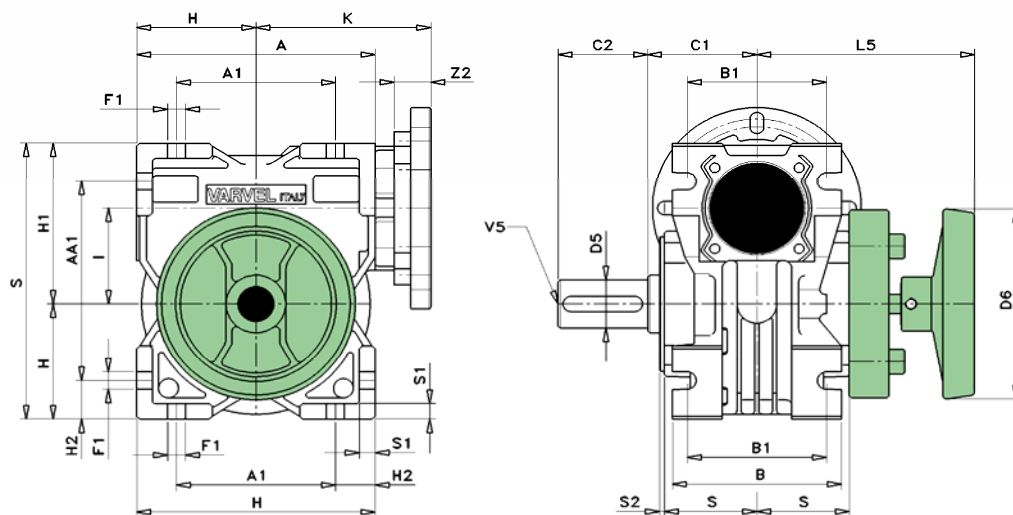

	RT28	RT40	RT50	RT60	RT70	RT85
A	80	100	120	144	172	206
A ₁	54	70	80	100	120	140
AA	97	121,5	144	174	205	238
AA ₁	71	91,5	104	130	153	172
B	53	71	85	100	112	130
B ₁	44	60	70	85	90	100
C ₁	31	51	59	70	70	71
C ₂	30	40	45	50	60	70
D _{5 (h6)}	14	19	25	25	28	35
D ₆	80	80	100	100	100	100
F ₁	7	7	9	9	11	13
H	40	50	60	72	86	103
H ₁	57	71,5	84	102	119	135
H ₂	13	15	20	22	26	33
I	28	40	50	60	70	85
K	57,5	70,5	83-88*	93-94*	117-118*	134-137*
L ₅	86	100	110	120	120	130
M ₅	16	21,5	28	28	31	44
N ₅	5	6	8	8	8	10
S	27,5	38,5	46,5	57	57	67
S ₁	6	7	8	10	11	14
S ₂	2,5	2,5	3	3	3	3
V ₅	M5x10	M8x20	M8x20	M8x20	M8x20	M10x25
Z ₂	13	13	13 - 18,5	14 - 15	15,5 - 17,5	15,5 - 18,5

* - IEC71-B14 (FRS50) - IEC71-B14 (FRS60) - IEC 80-B14 (FRS70) - IEC 90-B14 (FRS85) - IEC100/112-B14 (FRS110)

Not binding dimensions

VARVEL - ASR

PART LIST

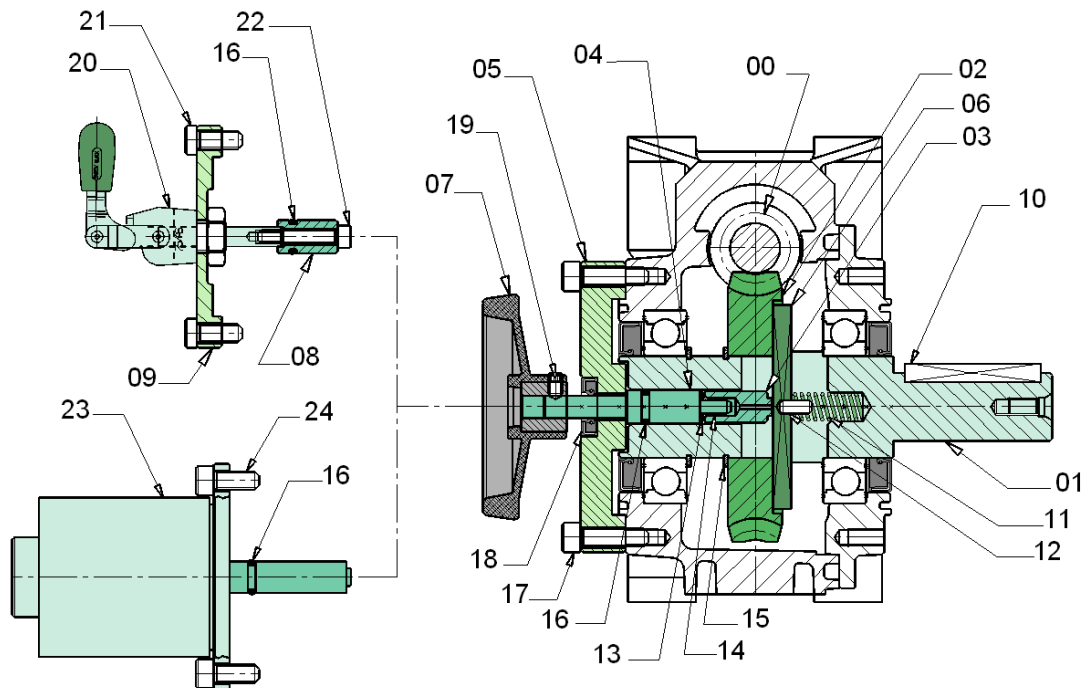

Item	Description	Item	Description
00	Wormshaft	13	Shim
01	Output shaft	14	Bush
02	Wormwheel	15	Seeger ring
03	Mobile control shaft	16	Oilseal OR
04	Fixed control shaft	17	Screw
05	Output cover	18	Oilseal
06	Key clutch	19	Screw
07	Control handwheel	20	Control lever
08	Lever control shaft	21	Screw
09	Lever output cover	22	Screw
10	Output shaft key	23	Electric solenoid
11	Spring	24	Screw
12	Key centring parallel pin		

VARVEL - ASR

Abstract of OPERATION AND MAINTENANCE INSTRUCTIONS

Variable speed and reduction gearboxes are not part of the field of application of the Machinery Directive, art.1(2), and they must not be put into service until the machinery into which they are to be incorporated, has been declared in conformity with the provision of art. 4(2), annex II(B) of Machinery Directives 98/37/CE and for Italy only, of DL 459/96.

The Instructions must be performed by trained and qualified personnel and, in case of Directive Atex, specifically experienced in potentially explosive zone safety.

Installation

Check if the unit to be installed, is properly selected to perform the required function and that its mounting position complies with the order. The nameplate reports such information. Check mounting stability to run the unit without vibrations or overloads.

Running

The unit may be connected for clockwise or counter-clockwise rotation.

The unit must be stopped as soon as defective running or unexpected noise occur, remove the faulty part or return the unit to the factory for checking. If the faulty part is not replaced, other parts can also be affected, causing more severe damage and making the identification of initial cause more difficult.

Maintenance

Although the units are no-load run tested in the factory before despatch, it is recommended not to run them at maximum load for the first 20-30 running hours to allow the proper running in.

The gearboxes are delivered already filled with long-life synthetic oil and, in case of replacement or topping, do not mix with mineral lubricants.

Handling

Attention, right positioning and stability when handling are essential to avoid subsequent damages in unit operation. When hoisting, use relevant housing locations or eyebolts if provided, or foot or flange holes. Never hoist on any moving part.

Painting

Carefully protect oil seals, coupling faces and shafts when units are re-painted.

Long-term storage

For storages longer than 3 months, apply anti-oxidants onto shafts and machined surfaces, and protective grease on oil seal lips.

Storages longer than one year reduce bearing grease lifetime.

Product's Environmental Management

In conformity with Environmental Certification ISO 14001, we recommend the following to dispose of our products:

- scraped components of the units to deliver to authorized centres for metal object collection;
- oils and lubricants drained from the units to deliver to Exhausted Oil Unions;
- packages (pallets, carton boxes, paper, plastic, etc.) to lead into regeneration/recycling circuits as far as possible, by delivering separate waste classes to authorized companies.